

Florida Department of Education
CURRICULUM FRAMEWORK

Program Title: Automotive Collision Repair and Refinishing
Occupational Area: Industrial Education

	<u>PSAV</u>	<u>Secondary</u>
Program Numbers	I470603	8709000
CIP Number	0647.060300	0647.060300
Grade Level	30, 31	9-12, 30, 31
Length	1400 hours	9 credits
SOC	49-3021	49-3021
Certification	AUTO IND @7G AUTO BODY @7G	AUTO IND @7G AUTO BODY @7G

I. MAJOR CONCEPTS/CONTENT: The purpose of this program is to prepare students for employment as automotive body, related repairers, automobile body repairers (SOC 49-3021).

The course content will include the following: basic trade skills; refinishing skills; sheetmetal repair skills; frame and unibody squaring and aligning; use of fillers; paint systems and undercoats; related welding skills; related mechanical skills; trim-hardware maintenance; glass servicing; and other miscellaneous repairs. The course content should also include training in communication, leadership, human relations and employability skills; and safe, efficient work practices.

This program focuses on broad, transferable skills and stresses understanding and demonstration of the following elements of the Automotive industry; planning, management, finance, technical and product skills, underlying principles of technology, labor issues, community issues, and health, safety and environmental issues.

II. LABORATORY ACTIVITIES: Shop or laboratory activities are an integral part of this program. These activities provide instruction in the use of tools, equipment, materials and processes found in the industry. Students are also instructed in the following: use of hand and power tools; panel repairs; use of spray equipment; use of frame and alignment equipment; application of body fillers; paint systems; use of shop materials; glass replacement; and use of MIG, oxyacetylene and plastic welders.

III. SPECIAL NOTE: SkillsUSA, Inc. is the appropriate Career and Technical Student Organization (CTSO) for providing leadership training and for reinforcing specific career and technical skills. Career and Technical Student Organizations, when provided, shall be an integral part of the career

and technical instructional program, and the activities of such organizations are defined as part of the curriculum in accordance with Rule 6A-6.065, FAC.

Cooperative training - OJT is appropriate for this program. Whenever cooperative training - OJT is offered, the following are required for each student: a training plan, signed by the student, teacher, and employer, which includes instructional objectives and a list of on-the-job and in-school learning experiences; a workstation that reflects equipment, skills and tasks that are relevant to the occupation which the student has chosen as a career goal. The student must receive compensation for work performed.

In accordance with Rule 6A-10.040, FAC, the minimum basic-skills grade levels required for adult vocational students to complete this program are: Mathematics 9.0, Language 9.0, Reading 9.0. These grade-level numbers correspond to grade-equivalent scores obtained on one of the state-designated basic-skills examinations. If a student does not meet the basic-skills level required for completion of the program, remediation should be provided through Vocational Preparatory Instruction (VPI). Please refer to the Rule for exemptions.

When a secondary student with a disability is enrolled in a vocational class with modifications to the curriculum framework, the particular outcomes and student performance standards, which the student must master to earn credit, must be specified on an individual basis. The job or jobs for which the student is being trained should be reflected in the student's desired postschool outcome statement on the Transition Individual Educational Plan (Transition IEP).

Federal and state legislation requires the provision of accommodations for students with disabilities to meet individual needs and ensure equal access. Adult students with disabilities must self-identify and request such services. Students with disabilities may need accommodations in such areas as instructional methods and materials, assignments and assessments, time demands and schedules, learning environment, assistive technology and special communication systems. Documentation of the accommodations requested and provided should be maintained in a confidential file.

To be transferable statewide between institutions, this program/course must have been reviewed, and a "transfer value" assigned the curriculum content by the appropriate Statewide Course Numbering System discipline committee. This does not preclude institutions from developing specific program or course articulation agreements with each other. Students who have mastered competencies, included in the Automotive Body Repair and Refinishing, should not be required to repeat those competencies.

This program may be offered in courses. Vocational credit shall be awarded to the student on a transcript in accordance with Section 1001.44 (3) (b) F.S.

The standard length of this program is 1400 hours.

Listed below are the courses that comprise this program at the secondary level:

8709010	Automotive Collision Repair and Refinishing 1 (150)
8709020	Automotive Collision Repair and Refinishing 2 (150)
8709030	Automotive Collision Repair and Refinishing 3 (150) OCP - A
8709040	Automotive Collision Repair and Refinishing 4 (150) OCP - B

8709050	Automotive Collision Repair and Refinishing 5 (150) OCP - C
8709060	Automotive Collision Repair and Refinishing 6 (150)
8709070	Automotive Collision Repair and Refinishing 7 (150) OCP - D
8709080	Automotive Collision Repair and Refinishing 8 (150)
8709090	Automotive Collision Repair and Refinishing 9 (150) OCP - E

IV. **INTENDED OUTCOMES:** After successfully completing the program, the student will be able to:

OCCUPATIONAL COMPLETION POINT - A (500 Hours)-- CORE
PAINT AND BODY HELPER (SOC 49-3021)

- 01.0 Demonstrate vehicle and industry knowledge, business management, and shop and occupational safety skills.
- 02.0 Prepare vehicles for repair and refinishing.
- 03.0 Repair, replace and adjust outer body panels.
- 04.0 Perform welding operations.
- 05.0 Prepare surfaces for refinishing.
- 06.0 Select and apply appropriate paints and finishes.
- 07.0 Demonstrate appropriate communication skills.
- 08.0 Demonstrate appropriate math skills.
- 09.0 Demonstrate appropriate understanding of basic science.
- 10.0 Demonstrate employability skills.
- 11.0 Demonstrate an understanding of entrepreneurship.

OCCUPATIONAL COMPLETION POINT - B (100 Hours)
AUTO COLLISION ESTIMATOR - (SOC 49-3021)

- 01.0 Demonstrate vehicle and industry knowledge, business management, and shop and occupational safety skills.
- 02.0 Prepare vehicles for repair and refinishing.

OCCUPATIONAL COMPLETION POINT - C (150 Hours)
FRAME AND BODY REPAIRMAN - (SOC 49-3021)

- 01.0 Demonstrate vehicle and industry knowledge, business management, and shop and occupational safety skills.
- 03.0 Repair, replace and adjust outer body panels.
- 12.0 Setup vehicle for measuring and pulling.
- 13.0 Inspect, measure and repair unibody vehicles.
- 14.0 Inspect and repair frame type vehicle bodies.

OCCUPATIONAL COMPLETION POINT - D (325 Hours)
AUTOMOTIVE REFINISHING - (SOC 49-3021)

- 01.0 Demonstrate vehicle and industry knowledge, business management, and shop and occupational safety skills.
- 05.0 Prepare surfaces for refinishing.
- 06.0 Select and apply appropriate paints and finishes.
- 15.0 Maintain and operate spray equipment.
- 16.0 Finish defects, causes and cures.

OCCUPATIONAL COMPLETION POINT - E (325 Hours)
AUTO BODY REPAIRER - (SOC 49-3021)

- 02.0 Prepare vehicles for repair and refinishing.

- 03.0 Repair, replace and adjust outer body panels.
- 04.0 Perform welding operations.
- 17.0 Prepare metal parts and panels for finishing.
- 18.0 Prepare and apply body fillers.
- 19.0 Perform miscellaneous repairs.
- 20.0 Repair fiberglass and plastic components.

The following diagram illustrates the program structure:

AUTOMOTIVE COLLISION REPAIR AND REFINISHING

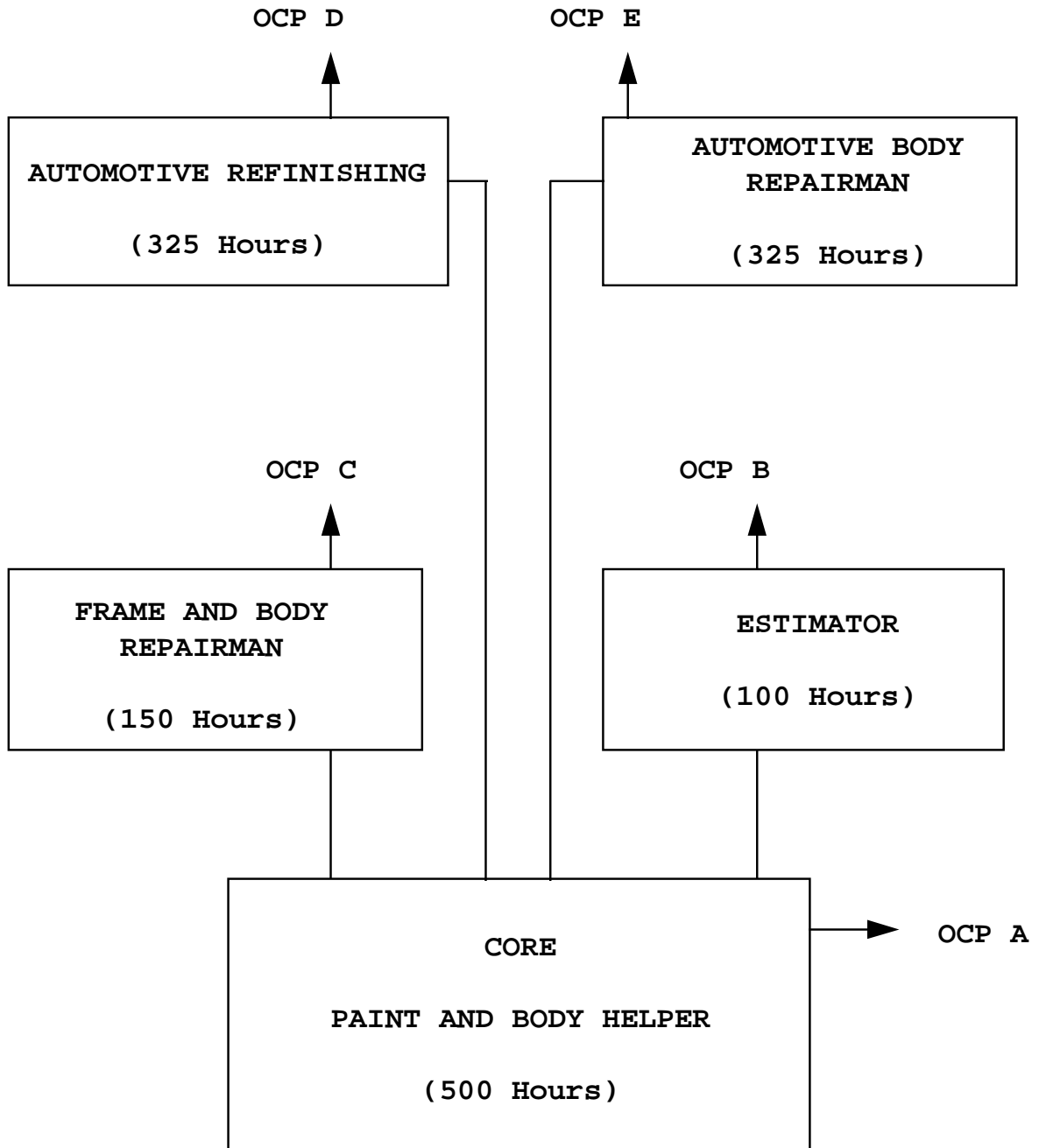

July 2007

Florida Department of Education
STUDENT PERFORMANCE STANDARDS

Program Title: Automotive Collision Repair and Refinishing
Postsecondary Number: I470603

CORE OCCUPATIONAL COMPLETION POINT - A
PAINT AND BODY HELPER

01.0 DEMONSTRATE VEHICLE AND INDUSTRY KNOWLEDGE, BUSINESS MANAGEMENT AND SHOP AND OCCUPATIONAL SAFETY SKILLS--The student will be able to:

- 01.01 Comply with safety rules established by OSHA, NIOSH, EPA, and DER regarding chemicals and hazardous materials.
- 01.02 Comply with safety rules established by OSHA and NIOSH regarding personal clothing and devices.
- 01.03 Comply with safety rules regarding hand tools and power equipment and use them properly, including fire extinguishers.
- 01.04 Comply with locally developed shop safety rules and regulations.
- 01.05 Identify sources of airborne contamination and other hazards.
- 01.06 Select proper spray mask; inspect the spray mask to insure proper fit and operation; inspect the condition of the mask filters and other components.
- 01.07 Explain the "Right to Know Law" as applicable to auto body repair occupations.
- 01.08 Identify vehicle parts by name, location and function.
- 01.09 Read and explain damage reports.

02.0 PREPARE VEHICLES FOR REPAIR AND REFINISHING--The student will be able to:

- 02.01 Remove, replace and align damaged outside trim and moldings.
- 02.02 Remove, replace and align damaged or necessary inside trim and moldings.
- 02.05 Remove, replace and align damaged, non-structural body panels and components that may interfere with or be damaged during repair.
- 02.04 Protect panels and parts adjacent to repair area to prevent damage.
- 02.04 Remove dirt, grease and wax from those areas to be repaired.
- 02.05 Remove dirt, corrosion, under coatings, sealers, and/or other protective coatings necessary to perform repairs to structural areas.
- 02.06 Remove, replace, and align repairable plastics and other parts that are recommended for off-car repair.
- 02.08 Locate, read and interpret automobile manufacturers' data plates.

03.0 REPAIR, REPLACE AND ADJUST OUTER BODY PANELS--The student will be able to:

- 03.01 Remove, replace and adjust a bolted panel or panel assembly.
- 03.02 Remove, replace and align hoods, hood hinges and hood latches.
- 03.03 Remove, replace and align deck lids, lid hinges and lid latches.
- 03.04 Remove, replace and align doors, tailgates, and hatches, lift gates and hinges.
- 03.05 Remove and replace bumpers, reinforcements, guards, isolators, and mounting hardware (release pressure from gas- and oil-filled energy-absorbing-type bumper isolators that are being discarded).

- 03.06 Check door hinge condition, replace hinge pins and bushings as needed, check door frames, check and adjust door clearances (where adjustable) along quarter panels, doors, rocker panels, fenders and tops.
 - 03.07 Check and adjust latch assemblies on all hinged components.
- 04.0 PERFORM WELDING OPERATIONS--The student will be able to:
- 04.01 Demonstrate welding safety procedures.
- 05.0 PREPARE SURFACES FOR REFINISHING--The student will be able to:
- 05.01 Inspect and identify types of finishes and surface conditions and develop a plan for refinishing using one paint system from start to finish in conformance with paint system manufacturer specifications.
 - 05.02 Gain access to, remove and store trim and molding.
 - 05.03 Remove dirt, wax and road grime from areas to be refinished and adjacent surfaces including complete washing of the vehicle.
 - 05.08 Mask and protect other areas that will not be refinished.
 - 05.09 Mix primer, primer surfacer or primer sealer and spray onto the surface of repaired areas including two components and self-etching primers.
 - 05.10 Apply glazing putty to minor surface imperfections.
 - 05.11 Select proper abrasives and dry or wet sand area to which primer-surfacer and glazing putty have been applied.
 - 05.12 Compound around the edges of repaired areas to be refinished.
 - 05.13 Remove dust from areas to be refinished including cracks or moldings of adjacent areas.
 - 05.14 Clean area to be refinished with a proper solution.
 - 05.15 Remove, with a tack rag, any dust or lint particles from the areas to be refinished.
- 06.0 SELECT AND APPLY APPROPRIATE PAINTS AND FINISHES--The student will be able to:
- 06.01 Sand, buff and polish finishes.
 - 06.02 Clean and detail a vehicle after completion of refinishing.
- 07.0 DEMONSTRATE APPROPRIATE COMMUNICATION SKILLS--The student will be able to:
- 07.01 Write logical and understandable statements, or phrases, to accurately fill out forms/invoices commonly used in business and industry.
 - 07.02 Read and understand graphs, charts, diagrams and tables commonly used in this industry/occupation area.
 - 07.03 Read and follow written and oral instructions.
 - 07.04 Answer and ask questions coherently and concisely.
 - 07.05 Read critically by recognizing assumptions and implications and by evaluating ideas.
 - 07.06 Demonstrate appropriate telephone/communication skills.
- 08.0 DEMONSTRATE APPROPRIATE MATH SKILLS--The student will be able to:
- 08.01 Solve problems for volume, weight, area, circumference and perimeter measurements for rectangles, squares and cylinders.

- 08.02 Measure tolerance(s) on horizontal and vertical surfaces using millimeters, centimeters, feet and inches.
 - 08.03 Add, subtract, multiply and divide using fractions, decimals and whole numbers.
 - 08.04 Determine the correct purchase price, including sales tax for a materials list containing a minimum of six items.
 - 08.05 Demonstrate an understanding of federal, state and local taxes and their computation.
- 09.0 DEMONSTRATE APPROPRIATE UNDERSTANDING OF BASIC SCIENCE--The student will be able to:
- 09.01 Understand molecular action as a result of temperature extremes, chemical reaction, and moisture content.
 - 09.02 Draw conclusions or make inferences from data.
 - 09.03 Identify health-related problems, which may result from exposure to work related chemicals and hazardous materials, and know the proper precautions required for handling such materials.
 - 09.04 Understand pressure measurement in terms of P.S.I., inches of mercury, and K.P.A.
- 10.0 DEMONSTRATE EMPLOYABILITY SKILLS--The student will be able to:
- 10.01 Conduct a job search.
 - 10.02 Secure information about a job.
 - 10.03 Identify documents, which may be required when applying for a job interview.
 - 10.04 Complete a job application form correctly.
 - 10.05 Demonstrate competence in job interview techniques.
 - 10.06 Identify or demonstrate appropriate responses to criticism from employer, supervisor or other employees.
 - 10.07 Identify acceptable work habits.
 - 10.08 Demonstrate knowledge of how to make appropriate job changes.
 - 10.09 Demonstrate acceptable employee health habits.
 - 10.10 Demonstrate a knowledge of the "Right-To-Know Law" as recorded in (29 CFR-1910.1200).
- 11.0 DEMONSTRATE AN UNDERSTANDING OF ENTREPRENEURSHIP--The student will be able to:
- 11.01 Identify characteristics of the American enterprise system.
 - 11.02 Define inflation and deflation.
 - 11.03 Illustrate the basic economic questions facing any society.
 - 11.04 Determine the results of a change in demand or a change in supply.
 - 11.05 List factors, which contribute to economic growth.
 - 11.06 Identify characteristics of different types of business ownership.
 - 11.07 Choose appropriate action in a situation requiring application of business ethics.

OCCUPATIONAL COMPLETION POINT - B

ESTIMATOR - (SOC 49-3021)

01.0 DEMONSTRATE VEHICLE AND INDUSTRY KNOWLEDGE, BUSINESS MANAGEMENT, AND SHOP AND OCCUPATIONAL SAFETY SKILLS--The student will be able to:

- 01.10 Operate basic office machines.
- 01.11 Demonstrate basic keyboarding skills and computer usage.
- 01.12 Determine acceptable parts to use: new, used or aftermarket.
- 01.13 Prepare damage reports manually to industry standards.
- 01.14 Prepare damage reports to industry standards using a computer.

02.0 PREPARE VEHICLES FOR REPAIR AND REFINISHING--The student will be able to:

- 02.09 Use specification and crash manuals including "P" pages.

OCCUPATIONAL COMPLETION POINT - C

FRAME REPAIRMAN - (SOC 49-3021)

01.0 DEMONSTRATE VEHICLE AND INDUSTRY KNOWLEDGE, BUSINESS MANAGEMENT AND SHOP AND OCCUPATIONAL SAFETY SKILLS--The student will be able to:

- 01.15 Perform structural damage analysis and determine repair procedures.

03.0 REPAIR, REPLACE AND ADJUST OUTER BODY PANELS--The student will be able to:

- 03.08 Determine the extent of damage to structural body panels; repair, weld, or replace in accordance with manufacturers' specifications.

12.0 SETUP VEHICLE FOR MEASURING AND PULLING--The student will be able to:

- 12.01 Determine and plan methods and order of repair.
- 12.02 Mount vehicle on anchoring equipment.
- 12.03 Measure vehicle damage using manufacturers' specifications.
- 12.04 Attach pulling equipment, pull and re-measure.

13.0 INSPECT, MEASURE AND REPAIR UNIBODY VEHICLES--The student will be able to:

- 13.01 Precisely measure unibody vehicles.
- 13.02 Diagnose and measure unibody damage using self-centering and tram gauges.
- 13.03 Diagnose and measure unibody damage using a datum plane.
- 13.04 Determine the location of all suspension, steering and power train component attaching point to the body.
- 13.05 Clean, prime and apply protective coat to repaired unibody structural areas.
- 13.06 Determine the extent of the direct and indirect damage and the direction of impact and plan the method and order of repair.
- 13.07 Precisely measure unibody vehicles, check and adjust suspension mount points that effect four-wheel alignment.

- 13.08 Diagnose and measure unibody damage using a dedicated (fixture) measuring system.
 - 13.09 Diagnose and measure unibody damage using a universal measuring system or a laser.
 - 13.10 Attach proper body anchoring devices.
 - 13.11 Identify procedures to straighten and align cowl assemblies.
 - 13.12 Identify procedures to straighten and align roof pillars and roof panels.
 - 13.13 Identify procedures to straighten and align doorposts, sills, floor pans and rocker panels.
 - 13.14 Identify procedures to straighten and align quarter panels, wheel-housing assemblies and rear body sections (including rail, suspension and power train panels).
 - 13.15 Identify procedures to straighten/align front-end sections (aprons, strut towers, upper/lower rails, steering, suspension and power train mounting points).
 - 13.16 Recognize the limitations of applying heat to high strength steel structural components, use proper heat stress relief methods on high strength steel and weld in accordance with manufacturers' specifications.
 - 13.17 Use proper cold stress relief methods.
 - 13.18 Remove folds, curves, creases and dents using power tools and hand tools to restore damaged areas to proper contours and dimensions.
 - 13.19 Determine the extent of damage to structural steel body panels and repair, weld or replace them in accordance with manufacturers' specifications.
 - 13.20 Determine the extent of damage to structural aluminum body panels in accordance with manufacturers' specifications.
 - 13.21 Cut out damaged sections of structural steel body panels and weld in new and/or used replacement in accordance with accepted industry standards.
 - 13.22 Recheck panel contour and alignment after pulling and correct or adjust as necessary.
- 14.0 INSPECT AND REPAIR FRAME TYPE VEHICLE BODIES--The student will be able to:
- 14.01 Diagnose and measure frame damage using self-centering and tram gauge.
 - 14.02 Determine the extent of direct and indirect damage and the direction of impact and plan methods and order of repairs.
 - 14.03 Clean, prime and protective coat repaired frame areas.
 - 14.04 Identify procedures to straighten and align mash damage.
 - 14.05 Identify procedures to straighten and align sag damage.
 - 14.06 Identify procedures to straighten and align side sway damage.
 - 14.07 Identify procedures to straighten and align twist damage.
 - 14.08 Identify procedures to straighten and align kickup damage.
 - 14.09 Identify procedures to straighten and align broadside damage.
 - 14.10 Identify procedures to straighten and align diamond frame damage.
 - 14.11 Identify procedures to remove and replace damaged frame horns, side rails, cross members and front or rear frame sections and weld cracks in frame members.
 - 14.12 Repair, reinforce or replace weakened frame members in accordance with vehicle manufacturers' recommendations.

OCCUPATIONAL COMPLETION POINT - D

AUTOMOTIVE REFINISHER - (SOC 49-3021)

01.0 DEMONSTRATE VEHICLE AND INDUSTRY KNOWLEDGE, BUSINESS MANAGEMENT AND SHOP AND OCCUPATIONAL SAFETY SKILLS--The student will be able to:

- 01.16 Inspect air makeup and exhaust systems (including intake filters, exhaust filters, fans and other mechanical components of the system) to insure proper filtering and ventilation.

05.0 PREPARE SURFACES FOR REFINISHING--The student will be able to:

- 05.15 Inspect and identify type of substrate, and surface condition; develop a plan for refinishing.
- 05.16 Chemically and mechanically remove paint finishes.
- 05.18 Dry and wet sand areas to be refinished.
- 05.19 Featheredge broken areas to be refinished.
- 05.20 Determine when sealing is needed or desirable and apply suitable sealer to the area being refinished.
- 05.21 Scuff sand to remove nibs or overspray from a sealer.
- 05.22 Apply adhesion promoter over areas to be painted and blend into adjacent areas.
- 05.23 Apply stone chip resistant coating.
- 05.24 Restore corrosion resistant coatings, caulking and seam sealers to repaired areas.

06.0 SELECT AND APPLY APPROPRIATE PAINTS AND FINISHES--The student will be able to:

- 06.03 Select the proper spray mask, inspect the spray mask to insure proper fit and operation, and inspect the condition of the mask filters and other components.
- 06.04 Determine the type and color of paint already on a vehicle and identify alternates.
- 06.05 Measure, shake, stir, thin or reduce, and strain paint.
- 06.06 Verify color match before applying and adjust if needed.
- 06.07 Apply acrylic enamel for spot, panel and overall refinishing.
- 06.08 Apply urethane enamel for spot, panel and overall refinishing.
- 06.09 Apply urethane clear coat for spot, panel and overall repairs.
- 06.10 Apply decals, transfers, tapes, wood-grains, pinstripes (painted and taped), etc.
- 06.11 Properly dispose of hazardous waste.
- 06.12 Identify the types of plastic parts to be finished and determine the proper refinishing procedure.
- 06.13 Apply a finish coat to plastic parts.
- 06.14 Clean, condition and refinish vinyl (e.g. upholstery, dashes and tops).
- 06.15 Apply a tri-coat paint system.

15.0 MAINTAIN AND OPERATE SPRAY EQUIPMENT--The student will be able to:

- 15.01 Explain, adjust and use a variety of spray guns including siphon feed, pressure feed, gravity feed and HVLP.
- 15.02 Check and adjust air pressure at the spray gun.
- 15.03 Adjust spray gun fluid and pattern control valves.

- 15.04 Use appropriate spray techniques (gun arc, gun angle, gun distance, gun speed, and spray pattern overlap) for the finish being applied.
- 15.05 Inspect, clean and determine the condition and adequacy of spray guns and related equipment (air hoses, regulators, airlines, air sources and spray environment).
- 15.06 Maintain and properly use the spray booth.

16.0 FINISH DEFECTS; CAUSES AND CURES--The student will be able to:

- 16.01 Check for rust spots; determine the cause(s) and correct the condition.
- 16.02 Identify paint cracking (crowsfeet or line-checking, micro checking, etc); correct the condition.
- 16.03 Identify poor adhesion; determine the cause(s) and correct the condition.
- 16.04 Identify blistering appearance in the paint surface; determine the cause(s) and correct the condition.
- 16.05 Identify water spotting on paint surface, correct the condition.
- 16.06 Identify finish damage caused by bird droppings, tree sap, and other natural causes; correct the condition.
- 16.07 Identify finish damage caused by airborne contaminants (acids, soot, and other industrial-related causes); correct the condition.
- 16.08 Identify die-back conditions (dulling of the paint film showing haziness and/or film distortion showing shrinking); correct the condition.
- 16.09 Identify chalking (oxidation); correct the condition.
- 16.10 Identify body filler bleed-through; correct the condition.
- 16.11 Identify pin holing; correct the condition.

OCCUPATIONAL COMPLETION POINT - E

AUTOMOTIVE BODY REPAIRMAN - (SOC 49-3021)

02.0 PREPARE VEHICLES FOR REPAIR AND REFINISHING--The student will be able to:

- 02.10 Diagnose and analyze damage to determine appropriate methods for overall repair.
- 02.11 Locate, remove and replace to specifications, those vehicle electrical/electronic devices that might be damaged during repair.
- 02.12 Explain proper air bag operation and passive restraint handling.

03.0 REPAIR, REPLACE AND ADJUST OUTER BODY PANELS--The student will be able to:

- 03.09 Remove, replace and align a welded (non-structural) steel panel or panel assembly.
- 03.10 Straighten roughed out contours of damaged panels to a surface condition for body filling or metal finishing.
- 03.11 Weld cracked or torn steel body panels; reweld broken welds.
- 03.12 Apply protective coatings and sealants to structural panels.
- 03.13 Heat shrink stretched panel areas back to contour.
- 03.14 Cold shrink stretched panel areas back to contour.
- 03.15 Repair or replace door skins and intrusion beams.

04.0 PERFORM WELDING OPERATIONS--The student will be able to:

- 04.02 Identify metal types prior to welding.
- 04.03 Setup, operate and maintain metal inert gas (MIG) welding equipment.
- 04.04 Perform various welds with MIG equipment including plug, butt and lap.
- 04.05 Setup and maintain oxyacetylene welding equipment.
- 04.06 Explain various welding, cutting and heating techniques with oxyacetylene equipment.
- 04.07 Describe plasma cutting.
- 04.08 Remove, replace and align damaged, structural body panels and components that may interfere with or be damaged during repairing.
- 04.09 Identify procedures to Weld aluminum.
- 04.10 Explain electric compression spot welding.
- 04.11 Set up and perform plasma-cutting operations.

17.0 PREPARE METAL PARTS AND PANELS FOR FINISHING--The student will be able to:

- 17.01 Identify specification(s) of metals used in automobiles.
- 17.02 Identify heat effects on metals.
- 17.03 Identify the importance of maintaining the structural integrity of an vehicle body.
- 17.04 Remove the paint from the damaged area of a body panel.
- 17.05 Pick and file the damaged area of a body panel to eliminate surface irregularities.
- 17.06 Disc sand the repaired body panel to produce final smoothness.

18.0 PREPARE AND APPLY BODY FILLERS--The student will be able to:

- 18.01 Mix plastic filler.
- 18.02 Apply plastic body filler and cheese grate during curing.
- 18.03 Block sand cured plastic body fillers to contour and then finish sand.

19.0 PERFORM MISCELLANEOUS REPAIRS--The student will be able to:

- 19.01 Align headlamps.
- 19.02 Apply rust repair methods including grinding, sandblasting and metal preparation.
- 19.03 Remove and replace headliners, carpets, seats and other interior components and trim.
- 19.04 Inspect, repair or replace weather stripping.
- 19.05 Identify procedures to perform two- and four- wheel alignments.
- 19.06 Diagnose and repair water leaks, dust leaks and wind noises.
- 19.07 Identify procedures to remove and replace all stationary glass (including windshield, back lights, etc.) using manufacturers' recommended installation materials and procedures including electrically heated glass.
- 19.08 Inspect, adjust, repair or replace window regulators, run channels, glass, power mechanism and related controls.
- 19.09 Repair/replace all power driven accessories and related controls.
- 19.10 Inspect, repair or replace and adjust removable manually operated or electrically operated roof panels, hinges, latches, guides, handles, retainers and controls of sunroof.

- 19.11 Diagnose and repair damaged circuits, wires and electrical components.
- 19.12 Remove, replace and cap off air conditioner components.
- 19.13 Evacuate, recycle and recharge air conditioning systems.
- 19.14 Identify procedures to remove and replace engines and mounts.
- 19.15 Identify procedures to remove and replace transmissions and mounts.
- 19.16 Identify procedures to remove and replace suspension parts.
- 19.17 Identify procedures to remove and replace brake parts.
- 19.18 Identify procedures to bleed brakes.
- 19.19 Identify procedures to remove and replace fuel system components.
- 19.20 Demonstrate an understanding of ABS braking systems.
- 19.21 Inspect, adjust or repair steering, suspension and power-train components that affect four-wheel alignment.

20.0 REPAIR FIBERGLASS AND PLASTIC COMPONENTS--The student will be able to:

- 20.01 Differentiate between fiberglass and sheet molded compound (SMC) to be repaired and the appropriate repair procedures (including plastic welding, chemical bonding and the use of structural adhesives).
- 20.02 Repair deep gouges and cracks in fiberglass panels and sheet molded compound (SMC).
- 20.03 Repair holes in fiberglass panels and SMC.
- 20.04 Repair fiberglass body panels and straighten/align panel supports.
- 20.05 Remove damaged areas from fiberglass panels and SMC and repair with partial panel installation.
- 20.06 Prepare the surfaces of and repair damage to, thermoplastic parts.
- 20.07 Prepare the surfaces of and repair damage to thermosetting-plastic parts.

July 2007

Florida Department of Education
STUDENT PERFORMANCE STANDARDS

SECONDARY

Program Number 8709000
CIP Number 0647.060300
Grade Level 9-12, 30, 31
Length 9 credits

Certification:

AUTO IND @7G
AUTO BODY @7G

Course Number: 8709010

Course Title: Automotive Collision Repair and Refinishing 1

Course Credit: 1

COURSE DESCRIPTION:

This course is designed to provide instruction in the different procedures for demonstrating shop and occupational safety skills and employability skills, and comprehending and complying with requirements concerning legal liability and consequent insurance implications.

CORE OCCUPATIONAL COMPLETION POINT - A

PAINT AND BODY HELPER - (SOC 49-9098)

01.0 DEMONSTRATE VEHICLE AND INDUSTRY KNOWLEDGE, BUSINESS MANAGEMENT AND SHOP AND OCCUPATIONAL SAFETY SKILLS--The student will be able to:

- 01.01 Comply with safety rules established by OSHA, NIOSH, EPA, and DER regarding chemicals and hazardous materials.
- 01.02 Comply with safety rules established by OSHA and NIOSH regarding personal clothing and devices.
- 01.03 Comply with safety rules regarding hand tools and power equipment and use them properly, including fire extinguishers.
- 01.04 Comply with locally developed shop safety rules and regulations.
- 01.05 Identify sources of airborne contamination and other hazards.
- 01.06 Select proper spray mask; inspect the spray mask to insure proper fit and operation; inspect the condition of the mask filters and other components.
- 01.07 Explain the "Right to Know Law" as applicable to auto body repair occupations.
- 01.08 Identify vehicle parts by name, location and function.
- 01.09 Read and explain damage reports.

02.0 PREPARE VEHICLES FOR REPAIR AND REFINISHING--The student will be able to:

- 02.01 Remove, replace and align damaged outside trim and moldings.
- 02.02 Remove, replace and align damaged or necessary inside trim and moldings.
- 02.05 Remove, replace and align damaged, non-structural body panels and components that may interfere with or be damaged during repair.

- 02.04 Protect panels and parts adjacent to repair area to prevent damage.
 - 02.04 Remove dirt, grease and wax from those areas to be repaired.
 - 02.05 Remove dirt, corrosion, under coatings, sealers, and/or other protective coatings necessary to perform repairs to structural areas.
 - 02.06 Remove, replace, and align repairable plastics and other parts that are recommended for off-car repair.
 - 02.08 Locate, read and interpret automobile manufacturers' data plates.
- 07.0 DEMONSTRATE APPROPRIATE COMMUNICATION SKILLS--The student will be able to:
- 07.01 Write logical and understandable statements, or phrases, to accurately fill out forms/invoices commonly used in business and industry.
 - 07.02 Read and understand graphs, charts, diagrams and tables commonly used in this industry/occupation area.
 - 07.03 Read and follow written and oral instructions.
 - 07.04 Answer and ask questions coherently and concisely.
 - 07.05 Read critically by recognizing assumptions and implications and by evaluating ideas.
 - 07.06 Demonstrate appropriate telephone/communication skills.
- 08.0 DEMONSTRATE APPROPRIATE MATH SKILLS--The student will be able to:
- 08.01 Solve problems for volume, weight, area, circumference and perimeter measurements for rectangles, squares and cylinders.
 - 08.02 Measure tolerance(s) on horizontal and vertical surfaces using millimeters, centimeters, feet and inches.
 - 08.03 Add, subtract, multiply and divide using fractions, decimals and whole numbers.
 - 08.04 Determine the correct purchase price, including sales tax for a materials list containing a minimum of six items.
 - 08.05 Demonstrate an understanding of federal, state and local taxes and their computation.

Florida Department of Education
STUDENT PERFORMANCE STANDARDS

Course Number: 8709020

Course Title: Automotive Collision Repair and Refinishing 2

Course Credit: 1

COURSE DESCRIPTION:

This course is designed to provide instruction in the different procedures for preparing vehicles for repair and refinishing and repair, replacement and adjustment of outer body panels.

03.0 REPAIR, REPLACE AND ADJUST OUTER BODY PANELS--The student will be able to:

- 03.01 Remove, replace and adjust a bolted panel or panel assembly.
- 03.02 Remove, replace and align hoods, hood hinges and hood latches.
- 03.03 Remove, replace and align deck lids, lid hinges and lid latches.
- 03.04 Remove, replace and align doors, tailgates, hatches, lift gates and hinges.
- 03.05 Remove and replace bumpers, reinforcements, guards, isolators, and mounting hardware (release pressure from gas- and oil-filled energy-absorbing-type bumper isolators that are being discarded).
- 03.06 Check door hinge condition, replace hinge pins and bushings as needed, check door frames, check and adjust door clearances (where adjustable) along quarter panels, doors, rocker panels, fenders and tops.
- 03.07 Check and adjust latch assemblies on all hinged components.

04.0 PERFORM WELDING OPERATIONS--The student will be able to:

- 04.01 Demonstrate welding safety procedures.

05.0 PREPARE SURFACES FOR REFINISHING--The student will be able to:

- 05.01 Inspect and identify types of finishes and surface conditions and develop a plan for refinishing using one paint system from start to finish in conformance with paint system manufacturer specifications.
- 05.02 Gain access to, remove and store trim and molding.
- 05.03 Remove dirt, wax and road grime from areas to be refinished and adjacent surfaces including complete washing of the vehicle.
- 05.08 Mask and protect other areas that will not be refinished.
- 05.09 Mix primer, primer surfacer or primer sealer and spray onto the surface of repaired areas including two components and self-etching primers.
- 05.10 Apply glazing putty to minor surface imperfections.
- 05.11 Select proper abrasives and dry or wet sand area to which primer-surfacer and glazing putty have been applied.
- 05.12 Compound around the edges of repaired areas to be refinished.
- 05.13 Remove dust from areas to be refinished including cracks or moldings of adjacent areas.
- 05.14 Clean area to be refinished with a proper solution.
- 05.15 Remove, with a tack rag, any dust or lint particles from the areas to be refinished.

09.0 DEMONSTRATE APPROPRIATE UNDERSTANDING OF BASIC SCIENCE--The student will be able to:

- 09.01 Understand molecular action as a result of temperature extremes, chemical reaction, and moisture content.
- 09.02 Draw conclusions or make inferences from data.
- 09.03 Identify health-related problems, which may result from exposure to work related chemicals and hazardous materials, and know the proper precautions required for handling such materials.
- 09.04 Understand pressure measurement in terms of P.S.I., inches of mercury, and K.P.A.

July 2007

Florida Department of Education
STUDENT PERFORMANCE STANDARDS

Course Number: 8709030

Course Title: Automotive Collision Repair and Refinishing 3

Course Credit 1

COURSE DESCRIPTION:

This course is designed to provide instruction in the different procedures for applying appropriate paints and finishes and a understanding of entrepreneurship.

06.0 SELECT AND APPLY APPROPRIATE PAINTS AND FINISHES--The student will be able to:

06.01 Sand, buff and polish finishes.

06.02 Clean and detail a vehicle after completion of refinishing.

10.0 DEMONSTRATE EMPLOYABILITY SKILLS--The student will be able to:

10.01 Conduct a job search.

10.02 Secure information about a job.

10.03 Identify documents, which may be required when applying for a job interview.

10.04 Complete a job application form correctly.

10.05 Demonstrate competence in job interview techniques.

10.06 Identify or demonstrate appropriate responses to criticism from employer, supervisor or other employees.

10.07 Identify acceptable work habits.

10.08 Demonstrate knowledge of how to make appropriate job changes.

10.09 Demonstrate acceptable employee health habits.

10.10 Demonstrate knowledge of the "Right-To-Know Law" as recorded in (29 CFR-1910.1200).

July 2007

Florida Department of Education
STUDENT PERFORMANCE STANDARDS

Course Number: 8709040

Course Title: Automotive Collision Repair and Refinishing 4

Course Credit: 1

COURSE DESCRIPTION:

This course is designed to provide instruction in procedures for occupational safety skills and prepare vehicles for repair.

11.0 DEMONSTRATE AN UNDERSTANDING OF ENTREPRENEURSHIP--The student will be able to:

- 11.01 Identify characteristics of the American enterprise system.
- 11.02 Define inflation and deflation.
- 11.03 Illustrate the basic economic questions facing any society.
- 11.04 Determine the results of a change in demand or a change in supply.
- 11.05 List factors, which contribute to economic growth.
- 11.06 Identify characteristics of different types of business ownership.
- 11.07 Choose appropriate action in a situation requiring application of business ethics.

OCCUPATIONAL COMPLETION POINT - B

ESTIMATOR - (SOC 49-3021)

01.0 DEMONSTRATE VEHICLE AND INDUSTRY KNOWLEDGE, BUSINESS MANAGEMENT, AND SHOP AND OCCUPATIONAL SAFETY SKILLS--The student will be able to:

- 01.10 Operate basic office machines.
- 01.11 Demonstrate basic keyboarding skills and computer usage.
- 01.12 Determine acceptable parts to use new, used or aftermarket.
- 01.13 Prepare damage reports manually to industry standards.
- 01.14 Prepare damage reports to industry standards using a computer.

02.0 PREPARE VEHICLES FOR REPAIR AND REFINISHING--The student will be able to:

- 02.09 Use specification and crash manuals including "P" pages.

July 2007

Florida Department of Education
STUDENT PERFORMANCE STANDARDS

Course Number: 8709050

Course Title: Automotive Collision Repair and Refinishing 5

Course Credit: 1

COURSE DESCRIPTION:

This course is designed to provide instruction in the different procedures for structural damage analysis and the repair of vehicle structure.

OCCUPATIONAL COMPLETION POINT - C

FRAME REPAIRMAN - (SOC 49-3021)

01.0 DEMONSTRATE VEHICLE AND INDUSTRY KNOWLEDGE, BUSINESS MANAGEMENT AND SHOP AND OCCUPATIONAL SAFETY SKILLS--The student will be able to:

01.15 Perform structural damage analysis and determine repair procedures.

03.0 REPAIR, REPLACE AND ADJUST OUTER BODY PANELS--The student will be able to:

03.08 Determine the extent of damage to structural body panels; repair, weld, or replace in accordance with manufacturers' specifications.

12.0 SETUP VEHICLE FOR MEASURING AND PULLING--The student will be able to:

- 12.01 Determine and plan methods and order of repair.
- 12.02 Mount vehicle on anchoring equipment.
- 12.03 Measure vehicle damage using manufacturers' specifications.
- 12.04 Attach pulling equipment, pull and re-measure.

13.0 INSPECT, MEASURE AND REPAIR UNIBODY VEHICLES--The student will be able to:

- 13.01 Precisely measure unibody vehicles.
- 13.02 Diagnose and measure unibody damage using self-centering and tram gauges.
- 13.03 Diagnose and measure unibody damage using a datum plane.
- 13.04 Determine the location of all suspension, steering and power train component attaching point to the body.
- 13.05 Clean, prime and apply protective coat to repaired unibody structural areas.
- 13.06 Determine the extent of the direct and indirect damage and the direction of impact and plan the method and order of repair.
- 13.07 Precisely measure unibody vehicles, check and adjust suspension mount points that effect four-wheel alignment.
- 13.08 Diagnose and measure unibody damage using a dedicated (fixture) measuring system.
- 13.09 Diagnose and measure unibody damage using a universal measuring system or a laser.
- 13.10 Attach proper body anchoring devices.

- 13.11 Identify procedures to straighten and align cowl assemblies.
- 13.12 Identify procedures to straighten and align roof pillars and roof panels.
- 13.13 Identify procedures to straighten and align doorposts, sills, floor pans and rocker panels.
- 13.14 Identify procedures to straighten and align quarter panels, wheel-housing assemblies and rear body sections (including rail, suspension and power train panels).
- 13.15 Identify procedures to straighten/align front end sections (aprons, strut towers, upper/lower rails, steering, suspension and power train mounting points).
- 13.16 Recognize the limitations of applying heat to high strength steel structural components, use proper heat stress relief methods on high strength steel and weld in accordance with manufacturers' specifications.
- 13.17 Use proper cold stress relief methods.
- 13.18 Remove folds, curves, creases and dents using power tools and hand tools to restore damaged areas to proper contours and dimensions.
- 13.19 Determine the extent of damage to structural steel body panels and repair, weld or replace them in accordance with manufacturers' specifications.
- 13.20 Determine the extent of damage to structural aluminum body panels in accordance with manufacturers' specifications.
- 13.21 Cut out damaged sections of structural steel body panels and weld in new and/or used replacement in accordance with accepted industry standards.
- 13.22 Recheck panel contour and alignment after pulling and correct or adjust as necessary.

14.0 INSPECT AND REPAIR FRAME TYPE VEHICLE BODIES--The student will be able to:

- 14.01 Diagnose and measure frame damage using self centering and tram gauge.
- 14.02 Determine the extent of direct and indirect damage and the direction of impact and plan methods and order of repairs.
- 14.03 Clean, prime and protective coat repaired frame areas.
- 14.04 Identify procedures to straighten and align mash damage.
- 14.05 Identify procedures to straighten and align sag damage.
- 14.06 Identify procedures to straighten and align side sway damage.
- 14.07 Identify procedures to straighten and align twist damage.
- 14.08 Identify procedures to straighten and align kickup damage.
- 14.09 Identify procedures to straighten and align broadside damage.
- 14.10 Identify procedures to straighten and align diamond frame damage.
- 14.11 Identify procedures to remove and replace damaged frame horns, side rails, cross members and front or rear frame sections and weld cracks in frame members.
- 14.12 Repair, reinforce or replace weakened frame members in accordance with vehicle manufacturers' recommendations.

July 2007

Florida Department of Education
STUDENT PERFORMANCE STANDARDS

Course Number: 8709060

Course Title: Automotive Collision Repair and Refinishing 6

Course Credit: 1

COURSE DESCRIPTION:

This course is designed to provide instruction in the different procedures for inspecting spray equipment and selection and application of finishes..

OCCUPATIONAL COMPLETION POINT - D

AUTOMOTIVE REFINISHER - (SOC 49-3021)

01.0 DEMONSTRATE VEHICLE AND INDUSTRY KNOWLEDGE, BUSINESS MANAGEMENT AND SHOP AND OCCUPATIONAL SAFETY SKILLS--The student will be able to:

01.16 Inspect air makeup and exhaust systems (including intake filters, exhaust filters, fans and other mechanical components of the system) to insure proper filtering and ventilation.

05.0 PREPARE SURFACES FOR REFINISHING--The student will be able to:

05.15 Inspect and identify type of substrate, and surface condition; develop a plan for refinishing.

05.16 Chemically and mechanically remove paint finishes.

05.18 Dry and wet sand areas to be refinished.

05.19 Featheredge broken areas to be refinished.

05.20 Determine when sealing is needed or desirable and apply suitable sealer to the area being refinished.

05.21 Scuff sand to remove nibs or overspray from a sealer.

05.22 Apply adhesion promoter over areas to be painted and blend into adjacent areas.

05.23 Apply stone chip resistant coating.

05.24 Restore corrosion resistant coatings, caulking and seam sealers to repaired areas.

06.0 SELECT AND APPLY APPROPRIATE PAINTS AND FINISHES--The student will be able to:

06.03 Select the proper spray mask, inspect the spray mask to insure proper fit and operation, and inspect the condition of the mask filters and other components.

06.04 Determine the type and color of paint already on a vehicle and identify alternates.

06.05 Measure, shake, stir, thin or reduce, and strain paint.

06.06 Verify color match before applying and adjust if needed.

06.07 Apply acrylic enamel for spot, panel and overall refinishing.

06.08 Apply urethane enamel for spot, panel and overall refinishing.

06.09 Apply urethane clear coat for spot, panel and overall repairs.

06.10 Apply decals, transfers, tapes, wood-grains, pinstripes (painted and taped), etc.

06.11 Properly dispose of hazardous waste.

- 06.12 Identify the types of plastic parts to be finished and determine the proper refinishing procedure.
- 06.13 Apply a finish coat to plastic parts.
- 06.14 Clean, condition and refinish vinyl (e.g. upholstery, dashes and tops).
- 06.15 Apply a tri-coat paint system.

July 2007

Florida Department of Education
STUDENT PERFORMANCE STANDARDS

Course Number: 8709070

Course Title: Automotive Collision Repair and Refinishing 7

Course Credit: 1

COURSE DESCRIPTION:

This course is designed to provide instruction in the different procedures for maintaining spray equipment and the causes of finish defects.

15.0 MAINTAIN AND OPERATE SPRAY EQUIPMENT--The student will be able to:

- 15.01 Explain, adjust and use a variety of spray guns including siphon feed, pressure feed, gravity feed and HVLP.
- 15.02 Check and adjust air pressure at the spray gun.
- 15.03 Adjust spray gun fluid and pattern control valves.
- 15.04 Use appropriate spray techniques (gun arc, gun angle, gun distance, gun speed, and spray pattern overlap) for the finish being applied.
- 15.05 Inspect, clean and determine the condition and adequacy of spray guns and related equipment (air hoses, regulators, air lines, air sources and spray environment).
- 15.06 Maintain and properly use the spray booth.

16.0 FINISH DEFECTS; CAUSES AND CURES--The student will be able to:

- 16.01 Check for rust spots; determine the cause(s) and correct the condition.
- 16.02 Identify paint cracking (crowsfeet or line-checking, micro-checking, etc); correct the condition.
- 16.03 Identify poor adhesion; determine the cause(s) and correct the condition.
- 16.04 Identify blistering appearance in the paint surface; determine the cause(s) and correct the condition.
- 16.05 Identify water spotting on paint surface, correct the condition.
- 16.06 Identify finish damage caused by bird droppings, tree sap, and other natural causes; correct the condition.
- 16.07 Identify finish damage caused by airborne contaminants (acids, soot, and other industrial-related causes); correct the condition.

July 2007

Florida Department of Education
STUDENT PERFORMANCE STANDARDS

Course Number: 8709080

Course Title: Automotive Collision Repair and Refinishing 8

Course Credit: 1

COURSE DESCRIPTION:

This course is designed to provide instruction in the different procedures for adjustment of outer body panels and welding operations.

16.0 FINISH DEFECTS; CAUSES AND CURES--The student will be able to:

- 16.08 Identify die-back conditions (dulling of the paint film showing haziness and/or film distortion showing shrinking); correct the condition.
- 16.09 Identify chalking (oxidation); correct the condition.
- 16.10 Identify body filler bleed-through; correct the condition.
- 16.11 Identify pin-holing; correct the condition.

OCCUPATIONAL COMPLETION POINT - E

AUTOMOTIVE BODY REPAIRMAN

02.0 PREPARE VEHICLES FOR REPAIR AND REFINISHING--The student will be able to:

- 02.10 Diagnose and analyze damage to determine appropriate methods for overall repair.
- 02.11 Locate, remove and replace to specifications, those vehicle electrical/electronic devices that might be damaged during repair.
- 02.12 Explain proper air bag operation and passive restraint handling.

03.0 REPAIR, REPLACE AND ADJUST OUTER BODY PANELS--The student will be able to:

- 03.09 Remove, replace and align a welded (non-structural) steel panel or panel assembly.
- 03.10 Straighten roughed out contours of damaged panels to a surface condition for body filling or metal finishing.
- 03.11 Weld cracked or torn steel body panels; reweld broken welds.
- 03.12 Apply protective coatings and sealants to structural panels.
- 03.13 Heat shrink stretched panel areas back to contour.
- 03.14 Cold shrink stretched panel areas back to contour.
- 03.15 Repair or replace door skins and intrusion beams.

04.0 PERFORM WELDING OPERATIONS--The student will be able to:

- 04.02 Identify metal types prior to welding.
- 04.03 Setup, operate and maintain metal inert gas (MIG) welding equipment.
- 04.04 Perform various welds with MIG equipment including plug, butt and lap.
- 04.05 Setup and maintain oxyacetylene welding equipment.

- 04.06 Explain various welding, cutting and heating techniques with oxyacetylene equipment.
- 04.07 Describe plasma cutting.
- 04.08 Remove, replace and align damaged, structural body panels and components that may interfere with or be damaged during repairing.
- 04.09 Identify procedures to Weld aluminum.
- 04.10 Explain electric compression spot welding.
- 04.11 Set up and perform plasma cutting operations.

July 2007

Florida Department of Education
STUDENT PERFORMANCE STANDARDS

Course Number: 8709090

Course Title: Automotive Collision Repair and Refinishing 9

Course Credit: 1

COURSE DESCRIPTION:

This course is designed to provide instruction in the different procedures for

17.0 PREPARE METAL PARTS AND PANELS FOR FINISHING--The student will be able to:

- 17.01 Identify specification(s) of metals used in automobiles.
- 17.02 Identify heat effects on metals.
- 17.03 Identify the importance of maintaining the structural integrity of an vehicle body.
- 17.04 Remove the paint from the damaged area of a body panel.
- 17.05 Pick and file the damaged area of a body panel to eliminate surface irregularities.
- 17.06 Disc sand the repaired body panel to produce final smoothness.

18.0 PREPARE AND APPLY BODY FILLERS--The student will be able to:

- 18.01 Mix plastic filler.
- 18.02 Apply plastic body filler and cheese grate during curing.
- 18.03 Block sand cured plastic body fillers to contour and then finish sand.

19.0 PERFORM MISCELLANEOUS REPAIRS--The student will be able to:

- 19.01 Align headlamps.
- 19.02 Apply rust repair methods including grinding, sandblasting and metal preparation.
- 19.03 Remove and replace headliners, carpets, seats and other interior components and trim.
- 19.04 Inspect, repair or replace weather stripping.
- 19.05 Identify procedures to perform two- and four- wheel alignments.
- 19.06 Diagnose and repair water leaks, dust leaks and wind noises.
- 19.07 Identify procedures to remove and replace all stationary glass (including windshield, back lights, etc.) using manufacturers' recommended installation materials and procedures including electrically heated glass.
- 19.08 Inspect, adjust, repair or replace window regulators, run channels, glass, power mechanism and related controls.
- 19.09 Repair/replace all power driven accessories and related controls.
- 19.10 Inspect, repair or replace and adjust removable manually operated or electrically operated roof panels, hinges, latches, guides, handles, retainers and controls of sun roof.
- 19.11 Diagnose and repair damaged circuits, wires and electrical components.
- 19.12 Remove, replace and cap off air conditioner components.

- 19.13 Evacuate, recycle and recharge air conditioning systems.
- 19.14 Identify procedures to remove and replace engines and mounts.
- 19.15 Identify procedures to remove and replace transmissions and mounts.
- 19.16 Identify procedures to remove and replace suspension parts.
- 19.17 Identify procedures to remove and replace brake parts.
- 19.18 Identify procedures to bleed brakes.
- 19.19 Identify procedures to remove and replace fuel system components.
- 19.20 Demonstrate an understanding of ABS braking systems.
- 19.21 Inspect, adjust or repair steering, suspension and power-train components that affect four-wheel alignment.

20.0 REPAIR FIBER GLASS AND PLASTIC COMPONENTS--The student will be able to:

- 20.01 Differentiate between fiberglass and sheet molded compound (SMC) to be repaired and the appropriate repair procedures (including plastic welding, chemical bonding and the use of structural adhesives).
- 20.02 Repair deep gouges and cracks in fiberglass panels and sheet molded compound (SMC).
- 20.03 Repair holes in fiberglass panels and SMC.
- 20.04 Repair fiberglass body panels and straighten/align panel supports.
- 20.05 Remove damaged areas from fiberglass panels and SMC and repair with partial panel installation.
- 20.06 Prepare the surfaces of and repair damage to, thermoplastic parts.
- 20.07 Prepare the surfaces of and repair damage to thermosetting-plastic parts.